

Model CL9

PARTS BREAKDOWN (continued)

Fig D. Synchronizer

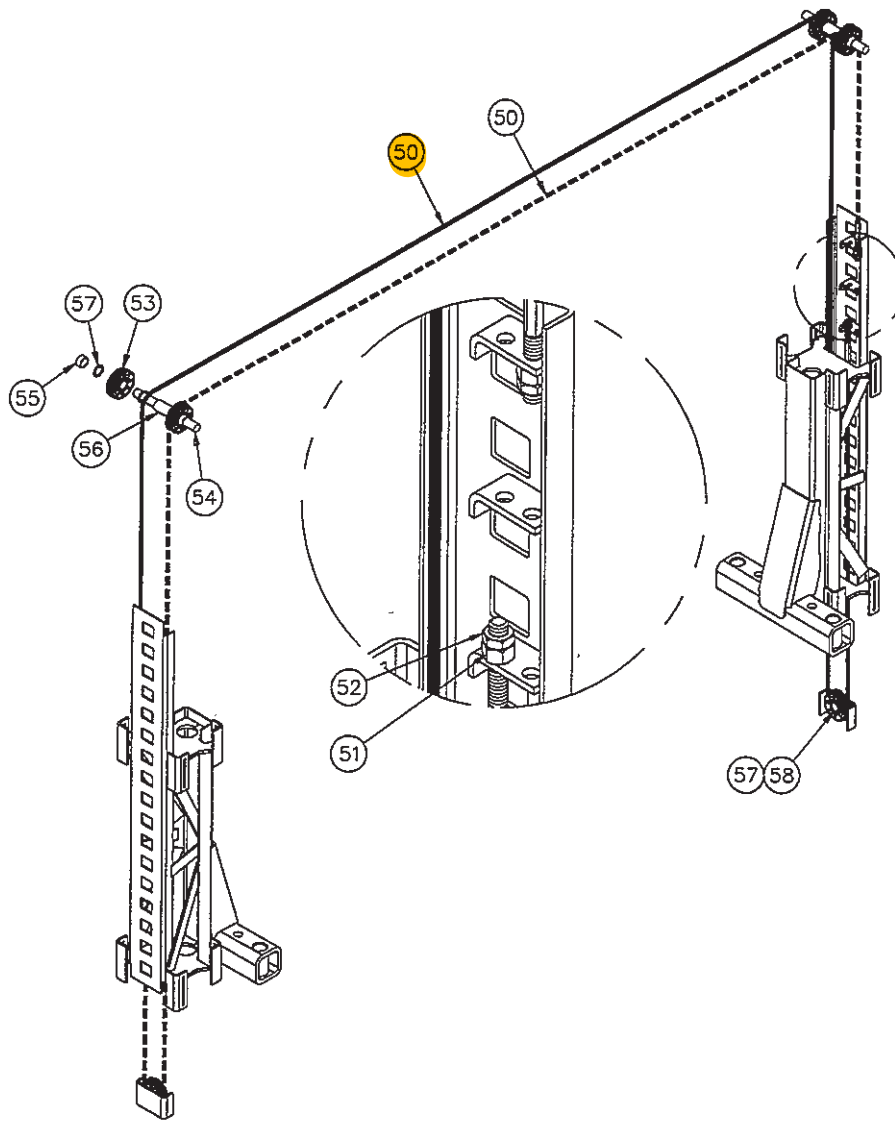

ITEM #	PART #	QTY/LIFT	DESCRIPTION
50	A1115-0	2	SYNCHRONIZER CABLE - CL9-0 (32'-8") [Cable Pack #A1003-0]
	A1115-1		SYNCHRONIZER CABLE - CL9-1 (34'-8") [Cable Pack #A1003-1]
	A1115-2		SYNCHRONIZER CABLE - CL9-2 (36'-8") [Cable Pack #A1003-2]
51	A1116	4	1/2-20NF HEX NUT
	A1117	4	1/2-20NF HEX JAM NUT
52	A1041	6	SHEAVE ASSEMBLY (3 1/2" DIA. X 1/4" GROOVE)
53	A1062	2	SHEAVE PIN
54	A1063-S	4	SHORT SHEAVE SPACER
55	A1063-L	2	LONG SHEAVE SPACER
56	36013	10	1" I.D. SPACER WASHER
57	36014	2	1" EXT. RETAINING RING

Replace all worn or broken parts with genuine **Challenger Lifts Inc.** parts.
Contact your local Challenger Lifts Parts Distributor