

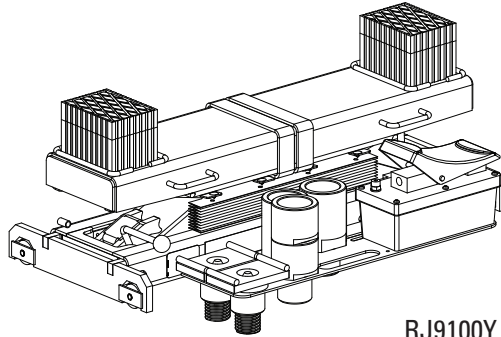

RJ9100Y, RJ9100Y-1, RJ9100Y-2 9000 lb. Rolling Jack

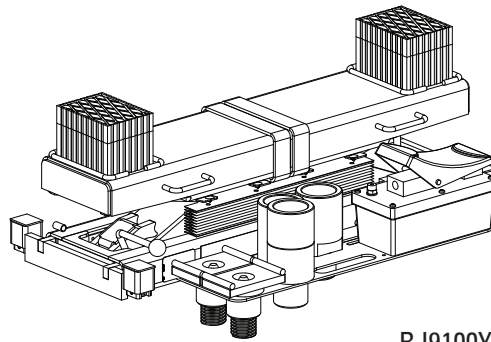

RJ9100Y



RJ9100Y-1

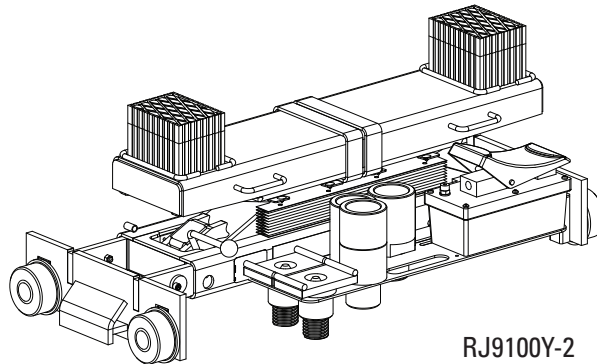

RJ9100Y-2

Table of Contents

Installation Instructions	3
Specifications	4
Safety Instructions	6
Operating Instructions	6
Maintenance Instructions	6
Trouble Shooting	7
Parts Breakdown	8

I
N
S
T
A
L
L
A
T
I
O
N
-
S
A
F
E
T
Y
-
O
P
E
R
A
T
I
O
N
-
M
A
I
N
T
E
N
A
N
C
E

The Owner/Employer:

- Shall ensure that lift operators are qualified and that they are trained in the safe use and operation of the lift using the manufacturer's operating instructions; *ALI/SM01-1, ALI Lifting it Right* safety manual; *ALI/ST-90 ALI Safety Tips* card; *ANSI/ALI ALOIM-2008, American National Standard for Automotive Lifts-Safety Requirements for Operation, Inspection and Maintenance*; *ALI/WL Series, ALI Uniform Warning Label Decals/Placards*; and in the case of frame engaging lifts, *ALI/LP-GUIDE, Vehicle Lifting Points/Quick Reference Guide for Frame Engaging Lifts*.
- Shall establish procedures to periodically inspect the lift in accordance with the lift manufacturer's instructions or *ANSI/ALI ALOIM-2008, American National Standard for Automotive Lifts-Safety Requirements for Operation, Inspection and Maintenance*; and The Employer Shall ensure that lift inspectors are qualified and that they are adequately trained in the inspection of the lift.
- Shall establish procedures to periodically maintain the lift in accordance with the lift manufacturer's instructions or *ANSI/ALI ALOIM-2008, American National Standard for Automotive Lifts-Safety Requirements for Operation, Inspection and Maintenance*; and The Employer Shall ensure that lift maintenance personnel are qualified and that they are adequately trained in the maintenance of the lift.
- Shall maintain the periodic inspection and maintenance records recommended by the manufacturer or *ANSI/ALI ALOIM-2008, American National Standard for Automotive Lifts-Safety Requirements for Operation, Inspection and Maintenance*.
- Shall display the lift manufacturer's operating instructions; *ALI/SM 93-1, ALI Lifting it Right* safety manual; *ALI/ST-90 ALI Safety Tips* card; *ANSI/ALI ALOIM-2008, American National Standard for Automotive Lifts-Safety Requirements for Operation, Inspection and Maintenance*; and in the case of frame engaging lifts, *ALI/LP-GUIDE, Vehicle Lifting Points/Quick Reference Guide for Frame Engaging Lifts*; in a conspicuous location in the lift area convenient to the operator.
- Shall provide necessary lockout/tagout means for energy sources per *ANSI Z244.1-1982 (R1993), Safety Requirements for the Lockout/Tagout of Energy Sources*, before beginning any lift repairs.
- Shall not modify the lift in any manner without the prior written consent of the manufacturer.

INSTALLATION INSTRUCTIONS

1. Place jack on runway tracks at front and rear with air pump, facing ends of runways. Adjust width of rolling jack to fit runway track. Make sure wheels are on the tracks. Center rolling jack between runways.
2. Install male quick-disconnect coupling in air pump to match shop fittings if required. Install filter/

regulator/lubricator, set to 100-120 psi and one drop of oil per minute. Capacity/serial no./model no. of rolling jack is stated on the nameplate.

Note: The bridge will consume 20cfm of air.

DO NOT OVERLOAD JACK.

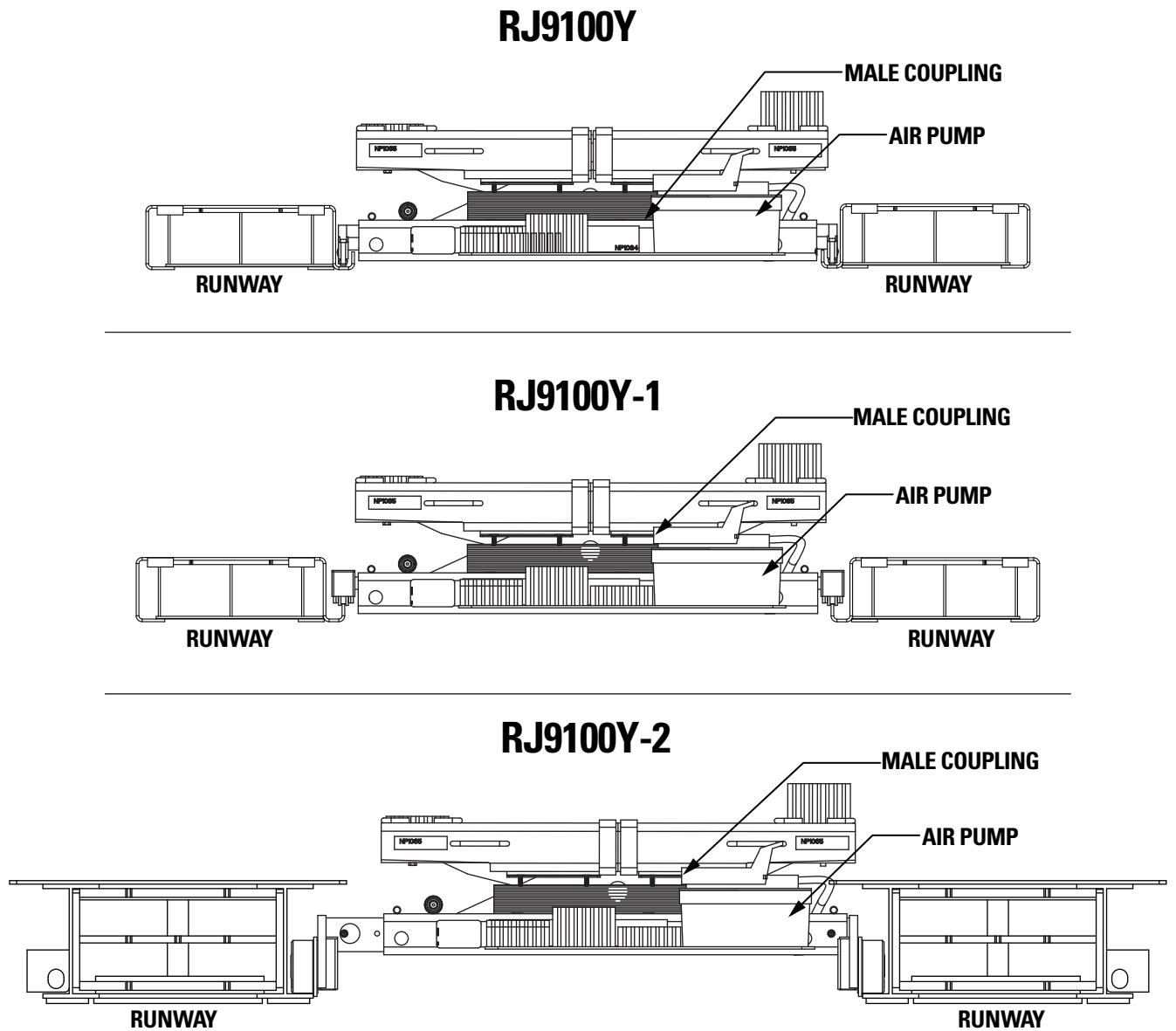

Fig. 1

General Description

The rolling jack assembly shall be an air operated, scissors style rolling jack assembly capable of lifting the wheels free of the runways for brake, suspension and tire service.

Description of installed equipment:

- A. Depending on model, the lifting capacity of the rolling jack shall be 9000 lbs. (4082 kg) when supplied with 100 psi (6.9 bar) minimum, 120 psi (8.3 bar) maximum regulated air at 20 CFM (0.57 m³/min.)
- B. RJ9100Y: The rail engaging wheels shall be adjustable for an inside runway width of 37 7/8" (962 mm) minimum to a 51 5/8" (1310 mm) maximum Fig. 2.
- C. RJ9100Y-1: The rail engaging wheels shall be adjustable for an inside runway width of 36 1/2" (926 mm) minimum to a 49 3/4" (1264 mm) maximum Fig. 3.
- D. RJ9100Y-2: The rail engaging wheels shall be adjustable for an inside runway width of 46 1/2" (1181 mm) minimum to a 56 1/8" (1425 mm) maximum Fig. 4.
- E. The rolling jack shall be equipped with three (3) different sized rubber pads 1/2", 1 1/2" and 3".
- F. The rolling jack shall be equipped with two (2) truck adapters, two (2) 3" adapter extensions, and two (2) 5" adapter extensions.
- G. The jack shall be equipped with a locking latch assembly that will lock at full-rise and that is released by actuating the lock handle.
- H. The scissor mechanism shall be covered by an accordion style rubber shield.
- I. The rolling jack shall be moveable on four (4) heavy duty urethane compression wheels. Actual vehicle load to be transferred to jack end section load bars engaging the roller track assembly.

***Specifications are subject to change without notice.**

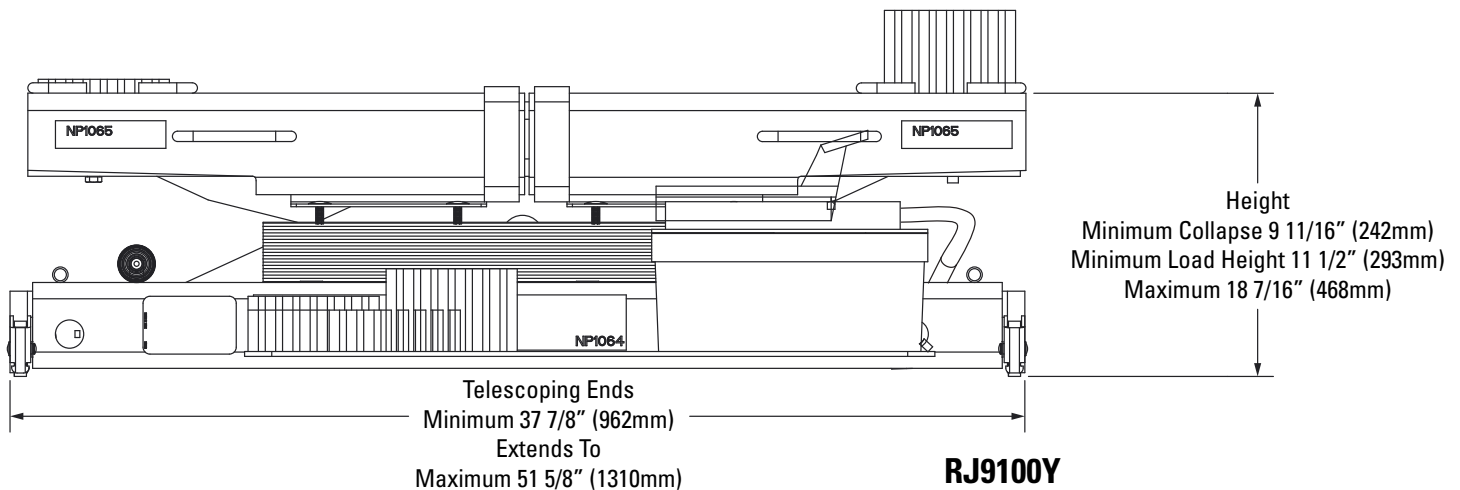

Fig. 2

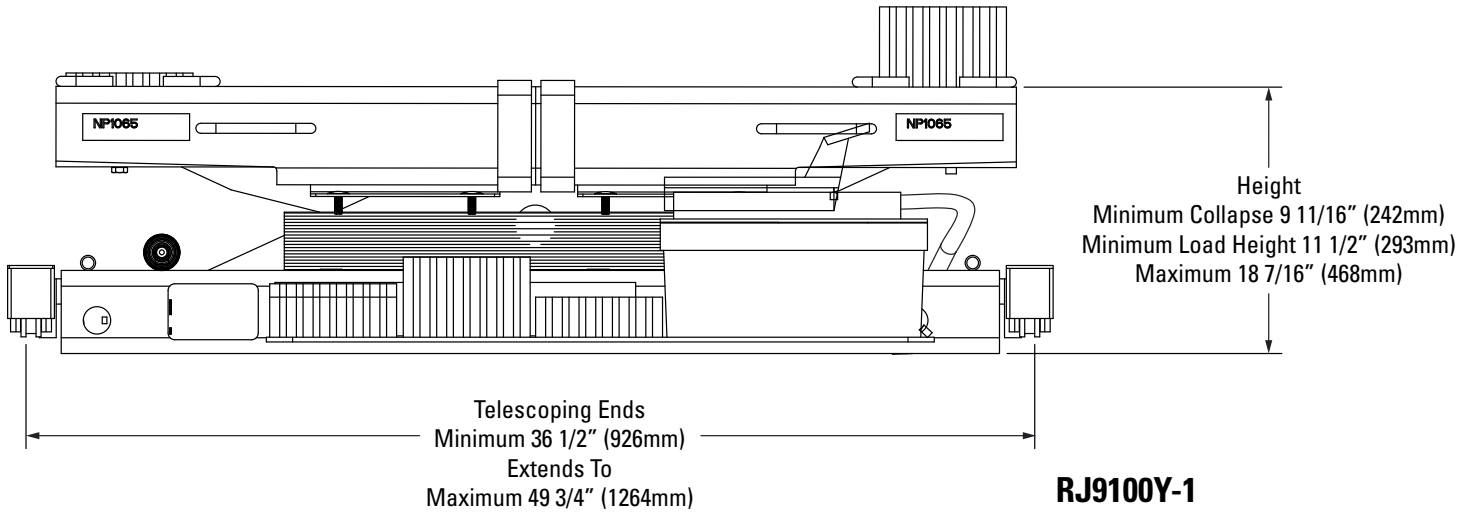

Fig. 3

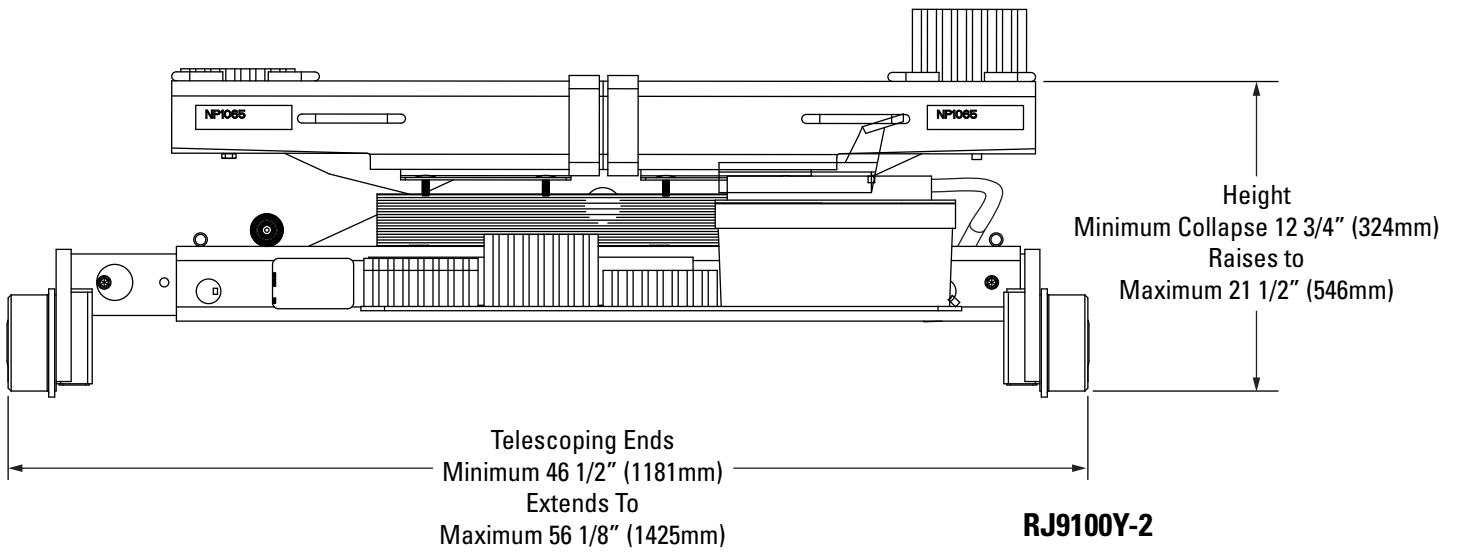

Fig. 4

SAFETY INSTRUCTIONS

- Never allow unauthorized or untrained persons to operate rolling jack.
 - Thoroughly train all employees in the use and care of rolling jack.
 - Never overload rolling jack. Capacity of rolling jack is stated on the nameplate. Capacity should not be exceeded.
 - Observe and avoid any pinch point areas of the linkage mechanism.
-

OPERATING INSTRUCTIONS

⚠WARNING To avoid personal injury and/or property damage, permit only trained personnel to operate jack. After reviewing these instructions, get familiar with jack controls by running the jack through a few cycles before loading vehicle on jack.

Observe and avoid any pinch point areas of the linkage mechanism.

1. Before loading a vehicle onto lift, ensure jack(s) are fully lowered. Make sure the adapters are in their most inbound and lowest position. Also ensure rear jack is toward the center of the lift.

⚠CAUTION Move rear jack toward center of runways of maximum vehicle clearance when loading and unloading vehicles.

⚠CAUTION Always fully lower jack(s) to prevent damage to the vehicle or lift.

2. After vehicle has been loaded, chock tires on the opposite side in which the rolling jack is to be used. If two rolling jacks are to be used, chock the tires on the opposite side of the rolling jack to be raised first.

⚠WARNING Engage runway locks before raising vehicle on jacks! **DO NOT** operate lift while jacks are engaged with a vehicle!

3. Place jack under vehicle at manufacturer's recommended pick-up points. Pull out the arms to the proper pick-up points. Take up clearance with rubber blocks.

Note: The rubber blocks can be stacked up 2 high.

⚠WARNING Do not stack rubber blocks or adapter extensions more than 2 high. Never set adapter blocks on edge. Load evenly; do not place weight on one side of the jack.

⚠CAUTION Allow 12" minimum clearance between vehicle and nearest overhead obstruction before raising vehicle above runways. Failure to comply could damage vehicle and/or cause personal injury.

4. **To Raise Rolling Jack:** Connect the air supply. Depress the pump lever and hold until the jack is raised to the desired lock position. Lift the pump lever to lower onto the locking latches.
5. **To Lower Rolling Jack:** Depress the pump lever to raise rolling jack off of the locking latches. Lift and hold latch release lever. Lift the pump lever until the jack lowers completely.

⚠CAUTION Always fully lower jack to prevent damage to the vehicle or lift.

Note: The Latch release handle is gravity return to "reset" and the lowering valve handle is spring return to "close" when released. Both must be held open during the lowering cycle. **DO NOT** override these "deadman" features.

4. Be sure the jack is fully lowered, the adapters are in their lowest position, and bridge(s) are pushed towards front of lift before driving the vehicle off the lift.

MAINTENANCE INSTRUCTIONS

⚠ WARNING If you are not completely familiar with automotive lift maintenance procedures STOP: Contact factory for instructions.

TO AVOID PERSONAL INJURY, permit only qualified personnel to perform maintenance on this equipment.

- Daily: Inspect rolling jack adapters for damage or excessive wear. Replace as required with original parts.
- Daily: Inspect air/hydraulic system for leaks.
- Daily: Inspect for loose bolts, broken/damaged components.
- Daily: Inspect linkage curtain guard for damage, wear and tear. Replace as required with original parts.
- Monthly: Inspect the roller assemblies.

- Semi-Annually: Check fluid level in hydraulic reservoir.

Fluid Level Checking Procedure:

1. Completely lower rolling jack.
2. Disconnect air supply.
3. Wipe reservoir clean to prevent contamination of fluid.
4. Remove fill plug and check fluid level. Fill as required to bottom of fill hole with ISO22 hydraulic fluid. Take care to prevent contamination during filling operation.
5. Reinstall plug hand tight only.

Note: Repair/Replace as required with original equipment parts.

TROUBLE SHOOTING

Trouble	Cause	Remedy
Pump will not start when air switch is depressed, or pump starts but stalls under load.	<ol style="list-style-type: none"> 1. Insufficient air supply at pump. 2. Leak in air supply line. 3. Restriction in air line (ie. kinks or plugs). 4. Plugged air filter. 5. Bad air motor. 	<ol style="list-style-type: none"> 1. Pump requires 100-120 psi of air @ 25 CFM to run. 2. Locate and correct leakage. 3. Locate and correct restriction. 4. Remove and install a new filter. 5. Repair or replace air motor.
Pump runs but lift will not raise after contacting load.	<ol style="list-style-type: none"> 1. Lift loaded beyond capacity. 2. External fluid leak at pump, hose or cylinder . 3. Internal leakage. 4. Release mechanism damaged or parts missing. 5. Wrong pump installed on lift. 6. Pump low on fluid. 7. Fluid blowing out rear cover of air motor. 8. Pump malfunctioning. 	<ol style="list-style-type: none"> 1. Use lift only to rated capacity. 2. Repair leak, refill reservoir.* 3. Have pump serviced by an authorized service center. 4. Replace damaged or missing parts. 5. Verify pressure rating of pumps meets pressure requirements of lift. 6. Lower lift and check fluid level. Fill with ISO22 hydraulic fluid. Locate and correct leak.* 7. Pump piston seal leaking, have pump serviced by an authorized service center. 8. Have pump serviced by an authorized service center.
Pump runs but lift will not raise to full height.	<ol style="list-style-type: none"> 1. Pump low on fluid. 	<ol style="list-style-type: none"> 1. Lower lift and check fluid level. Fill with ISO22 hydraulic fluid. Locate and correct leak.*
Lift drifts down - will not hold.	<ol style="list-style-type: none"> 1. Release mechanism damaged or parts missing. 2. External leakage. 3. Internal leakage. 	<ol style="list-style-type: none"> 1. Replace damaged or missing parts. 2. Locate leak and repair. Refill reservoir.* 3. Have pump serviced by an authorized service center.



* - Do not overfill reservoir. Lift must be completely lowered prior to adding fluid.

TROUBLE SHOOTING continued

Trouble	Cause	Remedy
Lift lowers slow or not at all.	<ol style="list-style-type: none"><li data-bbox="618 212 1036 241">1. Lift locking latch not released.<li data-bbox="618 249 1068 321">2. Release mechanism damaged or parts missing.<li data-bbox="618 329 1068 401">3. Return flow of fluid restricted or blocked. <li data-bbox="618 632 1068 701">4. Internal return flow restrictor is plugged.	<ol style="list-style-type: none"><li data-bbox="1105 212 1425 241">1. Release locking latch.<li data-bbox="1105 249 1515 321">2. Replace damaged or missing parts.<li data-bbox="1105 329 1552 625">3. Eliminate blockage. ⚠ WARNING If rolling jack is in the raised position, be sure to activate the mechanical locking device prior to attempting to service the unit. Failure to do so may cause lift to drop out of control.<li data-bbox="1105 632 1479 701">4. Have pump repaired by an authorized service center.

Parts Breakdown

ITEM	QTY	PART NO.	DESCRIPTION
1	3	40064	1/4-20NC X 3/8 SET SCR
2	4	41462	M8x1.25 x 20mm Lg. HHCS
3	2	41563	M8x1.25 HEX NYLON INSERT LOCKNUT
4	2	FC5144-1	BELLOWS
5	1	FC5185-45	45 DEGREE ELBOW
6	16	FC5185-69	RETAINER
7	1	FC5972	ROLLING BRIDGE PUMP 290 BAR
8	2	FJ2427Y	SPACER BLOCK 1 1/2" (38.1mm)
9	2	FJ2428Y	SPACER BLOCK 3" (76.2mm)
10	2	FJ71011Y	TRUCK ADAPTER ASSEMBLY
11	2	FJ71013Y	5" ADAPTER EXTENSION ASM
12	1	LP20672	RJ9001 INSTALLERS PACKAGE
13	1	NP1064	NAMEPLATE, ROLLING BRIDGE
14	2	NP1065	LABEL RETRACT ADAPTERS
15	1	NP909	LIFT NAMEPLATE
16	1	RJ7000-9801-1	HOSE
17	1	RJ7000-9802-1	STRAIGHT FITTING
18	1	SB300120	LINK ASSEMBLY
19	1	SB500083Y	UPPER CYLINDER SHAFT
20	1	SB500084Y	LOWER CYLINDER SHAFT
21	1	SB500158	LOCK ASSEMBLY, ROLLING JACK
22	1	SB500167	PIN
23	2	SB500177	M6X6 SCREW
24	1	SB500224	BOTTOM CHANNEL WELDMENT
25	1	SB500230	TOP CHANNEL WELDMENT
26	2	SB500232	SLIDING ADAPTER WELD
27a	2	SB500238	TELESCOPING ARM WHEEL ASSEMBLY
27b	2	FC635-1Y	TELESCOPING ARM WHEEL ASSEMBLY
27c	2	FC5980	TELESCOPING ARM WHEEL ASSEMBLY
28	2	SB500241	5" ADAPTER EXTENSION
29	1	SB700027Y	CYLINDER
30	2	SB700030Y	TOP SLIDER
31	2	SB700031Y	SLIDER
32	2	SB700057Y	SLEEVE BEARING
33	4	SB700060Y	6mm DIA. x 1" Lg. ROLL PIN
34	2	SB500241	3" ADAPTER EXTENSION

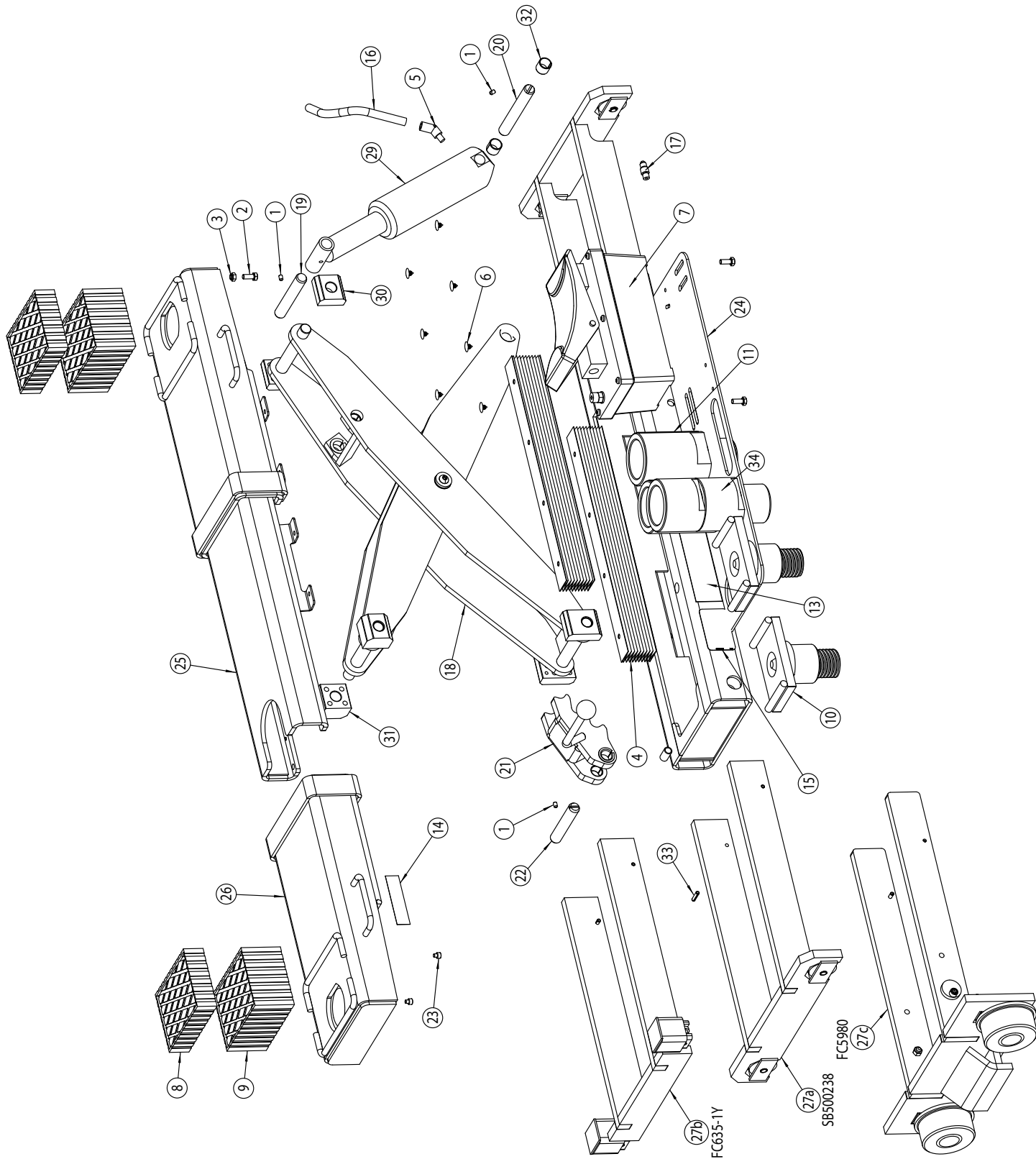

Link Weldment Detail SB300120 Link Assembly

ITEM	QTY	PART NO.	DESCRIPTION
1	2	B25-M10-20	BOLT M10x1.5x20MM BHCS
2	1	SB500127Y-1	PIN
3	2	SB500127Y-2	WASHER
4	1	SB500152	RJ INNER LEG ASSEMBLY
5	1	SB500227	RJ OUTER LEG ASSEMBLY
6	2	SB700036Y	NARROW TALL SLIDER

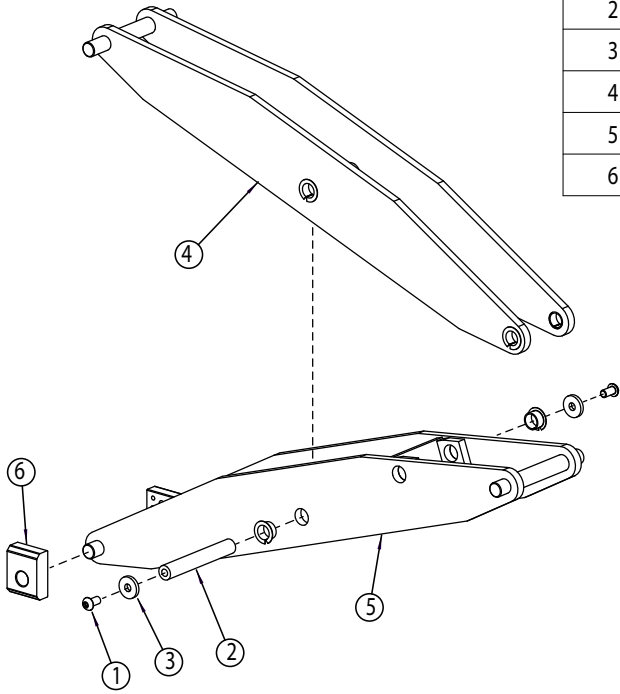

SB500238

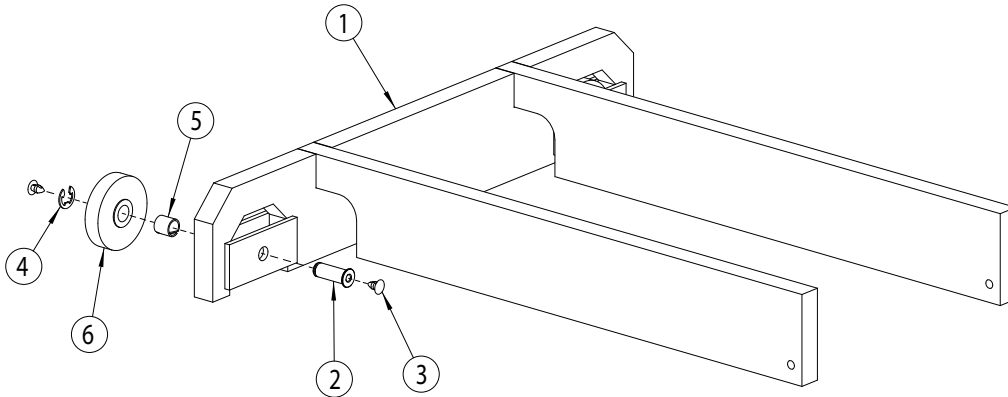

ITEM	QTY	PART NO.	DESCRIPTION
1	1	SB500239	TELESCOPING ARM WELDMENT
2	2	SB500176	SHAFT
3	4	SB700001Y	BUMPER
4	2	SB700002Y	WHEEL CLIP
5	2	SB700003Y	WHEEL BEARING
6	2	SB700005Y	URETHANE WHEEL

FC635-1Y

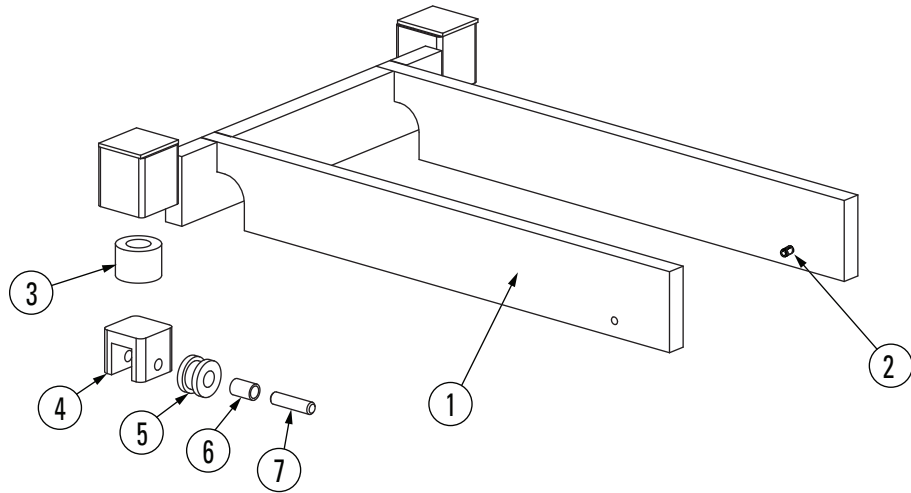

ITEM	QTY	PART NO.	DESCRIPTION
1	1	FC635-2Y	TELESCOPING END WHEEL WELD
2	2	SB300060Y	60mm DIA. x 1" Lg. ROLL PIN
3	2	FC5960-4	TELESCOPING END SPRING
4	4	FC5895-7	AXLE SUPPORT
5	2	FC5895-9	ROLLER
6	2	SS1216-12	SYMMCO BRONZE BEARING
7	2	FC5895-10	AXLE

FC5980

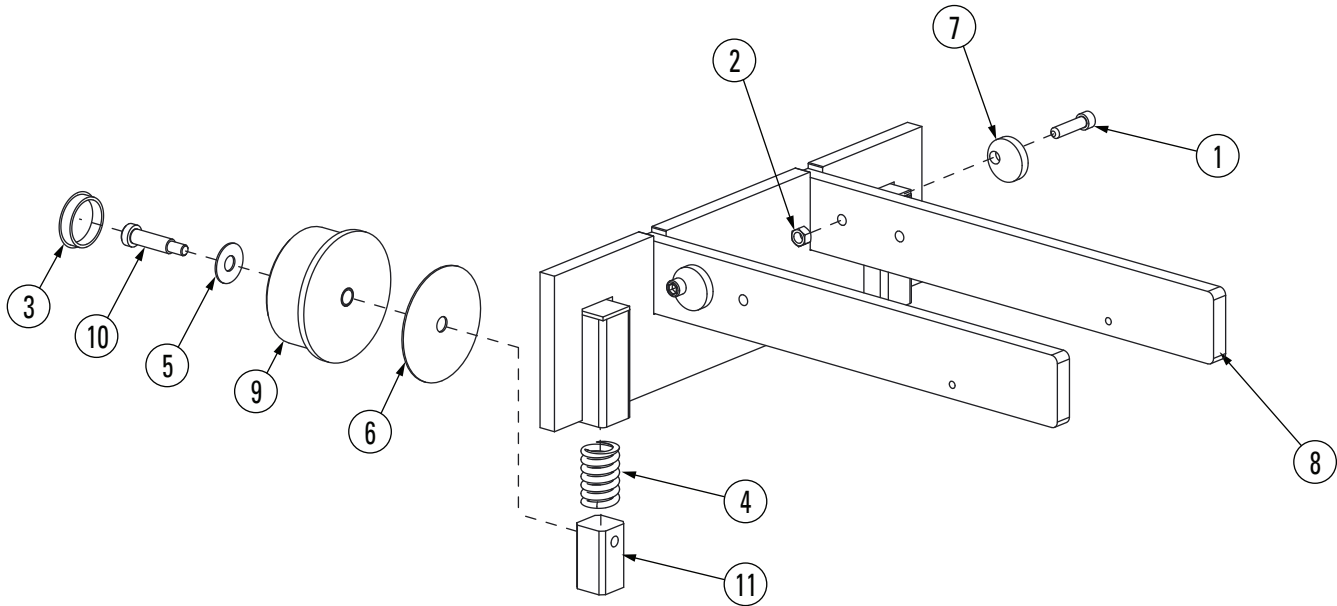

ITEM	QTY	PART NO.	DESCRIPTION
1	2	40197	3/8"-16NC x 1-1/2" Lg. HEX SHCS
2	2	40659	3/8"-16NC HEX NUT, PLTD, GRD5
3	2	41360	CAP
4	2	FC5277-10	SPRING
5	2	FC5277-20	WASHER
6	2	FC5341-28	BEARING
7	2	FC5959-4	CAM LOCK
8	1	FC5980-2	TELESCOPING END WELD RJ900Y-2
9	2	FC67-15	WHEEL ASSEMBLY
10	2	FC67-27	AXLE
11	2	FC67-28	INNER GUIDE

NOTES

Installer: Please return this booklet to literature package, and give to lift owner/operator.

Thank You

Trained Operators and Regular Maintenance Ensures Satisfactory Performance of Your Rotary Lift.

Contact Your Nearest Authorized Rotary Parts Distributor for Genuine Rotary Replacement Parts. See Literature Package for Parts Breakdown.

Rotary World Headquarters

2700 Lanier Drive
Madison, IN 47250, USA
www.rotarylif.com

North America Contact Information

Tech. Support:
p 800.445.5438
f 800.578.5438
e userlink@rotarylif.com
Sales:
p 800.640.5438
f 800.578.5438
e userlink@rotarylif.com

World Wide Contact Information

World Headquarters/USA: 1.812.273.1622
Canada: 1.905.812.9920
European Headquarters/Germany: +49.771.9233.0
United Kingdom: +44.178.747.7711
Australasia: +60.3.7660.0285
Latin America / Caribbean: +54.3488.431.608
Middle East / Northern Africa: +49.771.9233.0

© Vehicle Service GroupSM

Printed in U.S.A., All Rights Reserved. Unless otherwise indicated, ROTARY, and all other trademarks are property of Dover Corporation and its affiliates.

